



1391 - MicroProx® Tag Proximity Ordering Form

Please ensure each required option has been checked with the appropriate choice to fulfill a completed order form.

* 1391 Base Model Part Number Worksheet (* = Required Fields)

* Programming (Check One)

- L - Programmed, Low Frequency (125 kHz). Specify Programming Information.
- N - Non-Programmed, Low Frequency (125 kHz). Programming Information Not Required.

* Front Packaging (Check One)

- S - Gray with HID Standard Artwork
- K - Black with HID Standard Artwork
- B - Plain Black Finish, (No Artwork)
- G - Plain Gray Finish, (No Artwork)
- C - Custom Artwork – Specify Custom Artwork Number¹

* Back Packaging³

- S - Adhesive Backing

* Tag Numbering² (Check One)

- M - Sequential Matching Internal/External (Inkjetted)
- N - No External Tag Numbering
- S - Sequential Internal/Sequential Non-Matching External (Inkjetted)
- R - Random Internal/Non-Matching Sequential External (Inkjetted)

* Slot Punch

- N - None

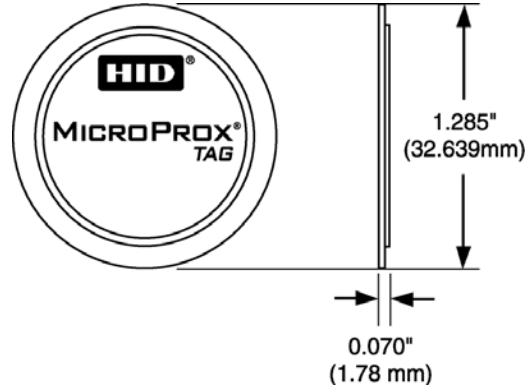

Optional Custom Artwork¹

_____ (Specify Artwork Number – Refer to the Custom Artwork Forms for new Artwork)

Please enter your final Tag options from check boxes above. Example: 1391LKSMN

* Final Part Number	1391			S		N	-	(Optional Artwork #)
---------------------	------	--	--	---	--	---	---	----------------------

* 125 kHz Tag Programming Information

Bit Numbers _____ (example: 26 bit) Format Number _____ (example: H10301)

Facility Code _____

(Custom Formats) Site Code _____ City Code _____ OEM Code _____

Internal Tag No. Start _____ Stop _____

External Tag No. Start _____ Stop _____

Special Instructions: _____

¹ For new artwork files, contact Customer Service for custom artwork number, lead-times, minimum order quantities, and cost.

² The external tag number is placed on the back of the tag.

³ The MicroProx Tag is not for use on cards that use full insertion or tractor feed type readers.

Do not adhere to metal surfaces. Metal shields the RF, making the tag inoperable. Due to variations in cards and reading devices, HID does not claim that the MicroProx Tag will work in every situation. Functional and non-functional MicroProx Tags are available for compatibility testing with existing credential and reader technologies. Compatibility should be confirmed prior to ordering.

MicroProx Placement

